

**LEGEND  
FITNESS™**

the **MODULAR**  
cage system



Pro Series Modular Half Cages  
with Fusion 1 Modules

**A customizable, integrated system of cages, connectors,  
and inserts that can expand and adapt to your needs.**

Why modular cages? Because the connecting crossmembers provide additional **pull-up areas/suspension training stations**, as well as **shared rigidity** above and beyond what single cages can provide. The integrated **Fusion Modules** give you even more versatility within a given footprint.

## Choose Cages

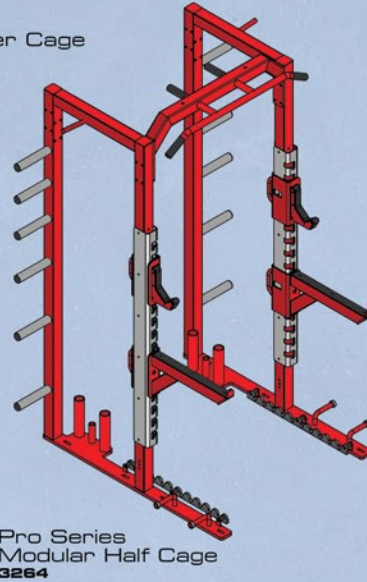
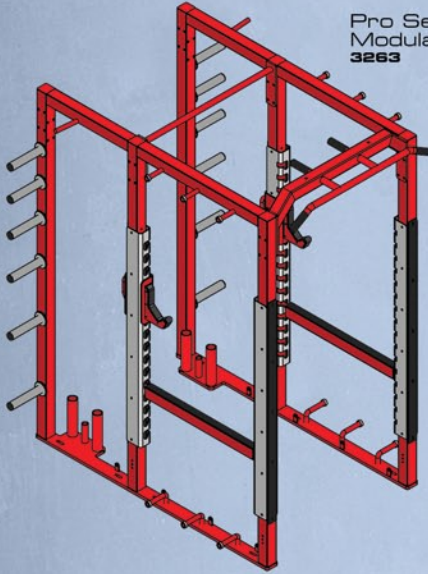

### Pro Series Modular Cage Specs

- 11 gauge, 3x3-inch frame
- 7 gauge, chrome-plated offset racking w/ laser-cut numbering
- Developed with 3D design software to use a minimal amount of fasteners
- Oversized, dual peg bar catches with number window and durable polymer contact surfaces
- 3x2-inch safety arms with ABS wearguards and an internal, full length, 1-inch racking rod
- 12 chrome-plated weight storage pegs
- Upright bar storage for up to 4 Olympic bars
- Band resistance/assistance pegs
- Floating wide grip pull-up bar, inside neutral grips, and attachment points for swivel grips
- Bench docking system is a no cost option
- Lifetime limited warranty on structural welds/frames
- Made in America

## Choose Fusion Modules

**Example:**  
Pro Series Modular Half Cage  
with  
Fusion 4 Destroyer Module

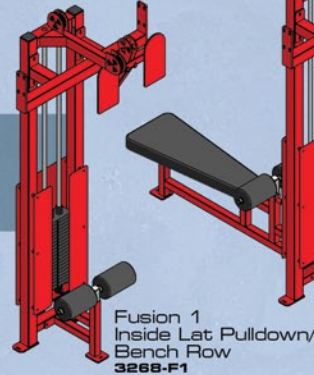

Fusion 3  
Adjustable  
Cable Column  
3268-F3

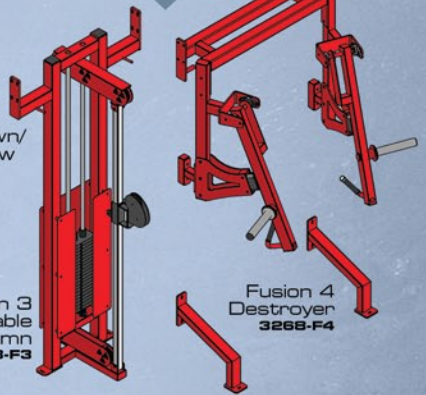

## Choose Connectors

